

REQUIREMENTS FOR RESIDENTIAL ELECTRIC SERVICE AND METER INSTALLATIONS



SAND MOUNTAIN ELECTRIC COOPERATIVE
POST OFFICE BOX 277, 402 MAIN STREET WEST
RAINSVILLE, ALABAMA 35986
256-638-2153

IF YOU HAVE ANY QUESTIONS REGARDING THESE REQUIREMENTS,
YOU WILL NEED TO CONTACT SMEC ENGINEERING DEPARTMENT TO
OBTAIN INFORMATION OR TO SET UP AN APPOINTMENT TO MEET A
STAKING ENGINEER. SMEC RECOMMENDS YOU CONTACT A
CERTIFIED ELECTRICIAN TO HELP WITH YOUR INSTALLATION.

2026 EDITION

SAND MOUNTAIN ELECTRIC COOPERATIVE
POST OFFICE BOX 277 - 402 MAIN STREET WEST
RAINSVILLE, ALABAMA 35986

FOR ADDITIONAL INFORMATION CALL THE
NUMBER LISTED BELOW:

RAINSVILLE -----256-638-2153

TABLE OF CONTENTS

GENERAL	3
STANDARD FORM OF SERVICE	3
CONNECTION OF SMEC SERVICE	4
LOCATION OF METER	5
GROUNDING	6
SERVICE ENTRANCE SWITCH GROUND	7
REGULATIONS FOR 3 WIRE ENTRANCE SERVICE	8
AUXILIARY POWER	9
BLOCK/BRICK/STUD CONSTRUCTION DIAGRAM	10
METER ON POLE INSTALLATION	11
TEMP RIG / METER ON POLE / CAMPER- DIAGRAMS	12-13
MOBILE HOME GUIDELINES	14
MOBILE HOME WIRING DIAGRAMS	15-16
MINIMUM CONDUIT AND WIRE SIZE	17-18
SPECIFICATIONS FOR UNDERGROUND SERVICE	19
SPECIFICATIONS FOR UNDERGROUND PRIMARY	20
H-STRUCTURE FOR UNDERGROUND SERVICE	21
PAD MOUNT TRANSFORMER OR JUNCTION PAD	22
ANTENNA SAFETY	23
FINAL INSPECTION	24

GENERAL

The rules in this booklet are intended to inform the consumer member of the Sand Mountain Electric Cooperative of the requirements for electric service. Requirements for safe wiring practices are not intended to conflict with the National Electric Code but shall be considered a supplement to the NEC. Building Contractors, electricians and others who are planning new construction or altering and rewiring existing structures should be familiar with these requirements before the work is planned or begun.

Any variance or exception to these requirements can only be made with the consent of the Sand Mountain Electric Cooperative. It is the intention of SMEC to be reasonable in its requirements and to work on a cooperative basis with all contractors so that satisfactory and economical electrical installation will be made.

In order to insure a uniform practice in the interest of all consumers and SMEC, it will be necessary for SMEC to refuse to connect to installations that does not conform to the requirements herein.

It will be necessary for the SMEC member to file a signed application for electric service. Final inspection of service entrance will be made by SMEC before the service can be connected and energized.

***SMEC reserves the right to charge a fee for inspection trips made after the initial inspection.**

Standard Form of Service

Electricity in the form of 60 cycle, alternating current is available for residential use to SMEC members for ordinary lighting and small power loads, in single phase, 3-wire, 4-wire approximately 120-240 volts only.

CONNECTION OF SMEC SERVICE CONDUCTORS TO A RESIDENCE

SMEC will investigate and designate the location of the point of attachment of the SMEC service conductors to the residence, and the cooperative will provide only one service connection. SMEC Construction Engineer will take meter base to the customer's site.

For any type of masonry such as brick, block, stucco, rock, etc., SMEC will furnish bolts for connecting service conductors to the structure. Any means provided for attachment of service conductors to the structure must be securely mounted to prevent any damage to the structure by the strain of the service conductors.

The mounting height of the connection point shall be a minimum of (12') twelve feet above ground to provide proper clearance for the service conductors, or a minimum of (15') fifteen feet where service crosses driveway and it is not subject to truck traffic.

For buildings or structures with a wall less than (12') twelve feet above ground, there shall be a service mast installation (2 ½ inch rigid metal conduit—minimum). The conduit installation shall be constructed strong enough to hold the service wires at an elevation of (12') twelve feet above the ground and shall be (15') fifteen feet where the service crosses a driveway and it is not subject to truck traffic.

The service mast shall extend a minimum of (24") twenty four inches above the roof to the top of the conduit to provide space for fastening service wires and said top of conduit shall be a minimum of (12') twelve feet above ground level.

Service mast installations above the roof line must have a minimum size of (2 ½") two and one half inch rigid metal conduit.

SMEC can furnish meter base with correct size hub but does not furnish outside disconnect box.

LOCATION OF METER

All residential metering shall be of the outside type and surface mounted. Any unusual application must be approved by SMEC before installation has begun. Please note the following:

THE ENGINEER DEPARTMENT OF SMEC MUST BE CONSULTED REGARDING THE CORRECT LOCATION FOR THE METER BASE.

1. Meter shall be installed at location designated by SMEC on the outside wall of the building structure. Enclosed porches are considered as being inside the building.
2. Meter must be accessible at all times to the meter reader and other Employees of SMEC.
3. Meter must not be more than (6') six feet nor less than (4) four feet above ground measured from the top of the meter socket.
4. Meter must not be in a location where it will be subject to the action of water running off a roof.

Meter bases shall be provided by SMEC engineer after they have spotted meter location.

- **All one or two family dwellings must now have outside disconnect box regardless if the meter base and inside panel are back to back.**

National Electric Code–Article 230.85
Required January 1, 2023

- **On any other structures, an outside disconnect box is required if meter base and inside panel are not back to back, which will require using a four wire entrance.**

National Electric Code–Article 230–part 1–6.
Required November 1, 2006

If further information is needed, contact SMEC Engineering Department.

GROUNDING

There are Three Types of grounding that are acceptable by Sand Mountain Electric Cooperative.

1. Grounding at the overhead neutral.
2. Grounding at the service entrance switch.
3. Grounding at the meter base.

SERVICE ENTRANCE SWITCH GROUND

A No. 4 AWG solid Copper ground conductor or larger shall be connected from the neutral connection on the power supply of the service panel and run through a drilled hole (slightly larger than the ground conductor) in the housing of the service panel to a conductor on the driven ground rod.

A ground conductor may also be run from the driven ground to an underground metal water pipe if available.

Conductors may be run through a wall but not vertically or laterally in a wall.

All grounding electrodes are to be commonly and directly connected together, electrical, communications, etc.

NOTE: ADEQUATE GROUNDING PROPERLY INSTALLED IS VERY IMPORTANT FOR PROTECTION OF PEOPLE AND EQUIPMENT.

REGULATIONS FOR 3-WIRE ENTRANCE SERVICES

Conduit or service entrance cable shall be terminated with an approved type weather head at a point of attachment to overhead conductors. Each conductor shall extend an adequate length (18" to 36") beyond the weather head to provide drip loop to overhead service conductors. The weather head shall be a minimum of (12') twelve feet above ground level.

Service conductors shall be sized in accordance with the National Electric Code to carry the connected load and may be determined from the tables at the end of this section.

Service entrance cable shall enter meter socket through approved bushing provided with permanently rain tight, compression-type glands. After all mechanical connections are securely made; the top connector should be given a coating of silicone chalk.

All entrance cable shall be run flat against the building and fastened with approved cable clamps, which are to be spaced not more than (2') two feet apart. Entrance cable shall not be used on metal structures: conduit must be used here.

Wood plugs are not approved on masonry walls for anchors. Lead or other approved type anchors shall be used.

All materials used on outside of consumer's premises on wall must be non-corrosive materials.

Service equipment shall be approved, solid neutral type with neutral bonded to switch frame, and dead -front type (shall have no exposed wiring while fuses are uncovered).

A 200-ampere service entrance may be one 200-ampere panel or 2-100ampere panels or a house power panel. (A house power panel is a combination meter socket and breaker panel with up to (6) six main disconnects (Ref Article 230 & 238, see NEC)

GENERATORS OR AUXILIARY POWER

Where auxiliary power is to be provided for various loads, permission from SMEC must be obtained before service connections will be made.

A service rated transfer switch, automatic or manual, **MUST** be provided for the purposes of isolating the two sources of power. All equipment installed and used shall be in accordance with National Electrical Code.

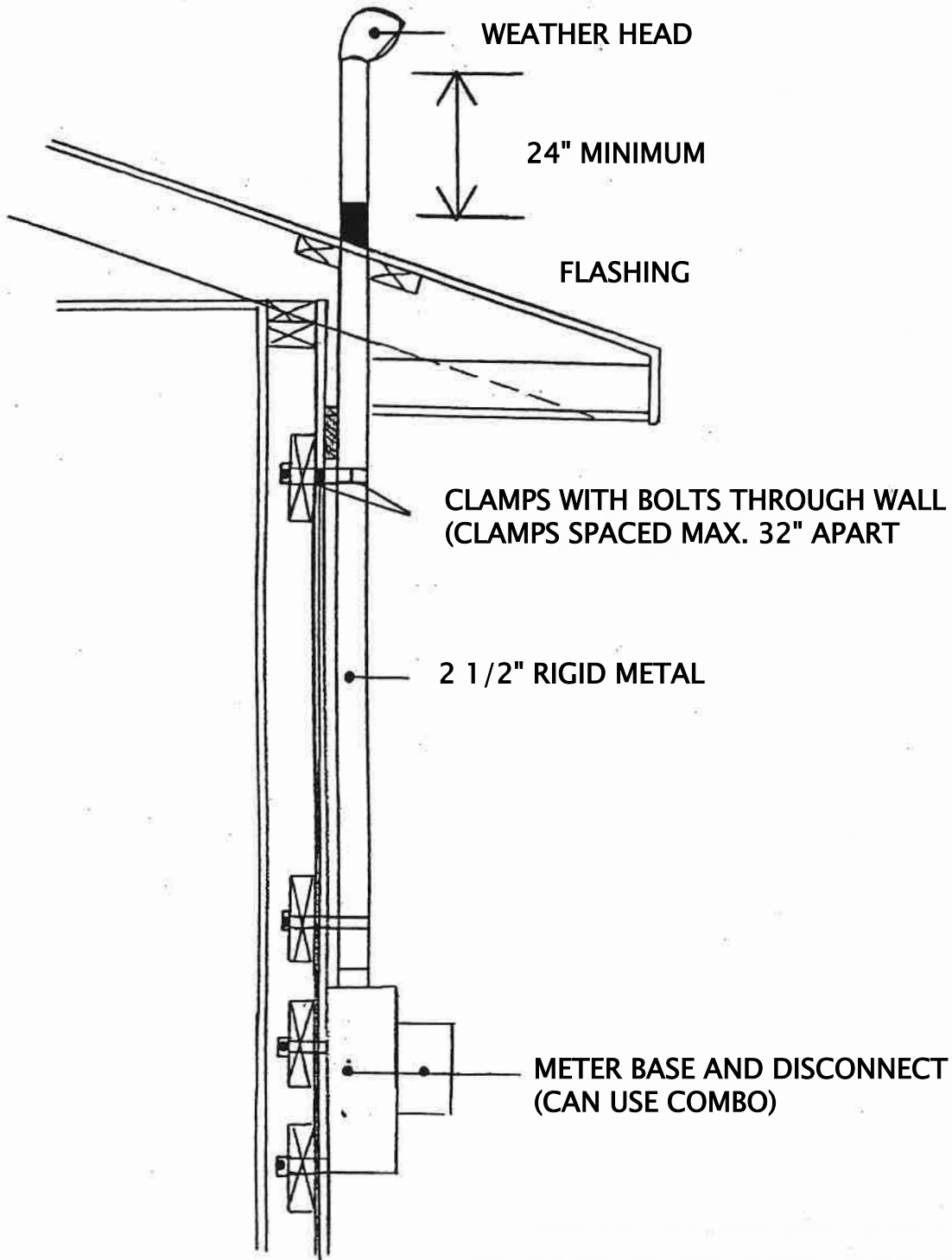

BLOCK / BRICK / STUD CONSTRUCTION

METER POLE INSTALLATION

Except under special applications approved by SMEC personnel, a disconnect means must be provided which shall be rain proof and dead front.

The meter socket shall be installed with the center of the socket not more than (6) six feet or less than (4) four feet from the ground.

When entrance cable is used, the cable shall have a weather head, installed thereon with adequately separated conductors (18" to 36") extending beyond the weather head, all completely made up with 1 ½ " non - corrosive screws for fastening the weather head firmly to the pole. The cable shall be fastened to the pole with the weather head being (24") two feet below SMEC secondary wire (low voltage). Clamps will be installed as needed but not more than (4) four feet apart.

When conduit is used, the weather head shall be (24") two feet below the lowest size of wires being used; secondary wire and sufficient wire shall extend from the weather head to reach the various SMEC conductors. The conduit shall be a size called for in the National Electrical Code for the number and size.

The ground wire shall be fastened to the pole (4) four feet below the secondary and (8) eight feet of wire above this point shall be left hanging for SMEC employees to make connection to the neutral. Wire shall be continuous to the ground rod, but may be tapped with a conductor to ground the switch box, which shall be grounded.

**POLE IS A 20' ROUND TREATED POLE WITH 4' IN GROUND
GROUND ROD IS 5/8 INCH, 8 FOOT GALVINIZED OR COPPER CLAD ROD**

**NOTE FOR INSTALLATION -
SEE DRAWING THAT FOLLOWS**

TEMPORARY RIG / METER ON POLE / CAMPER INSTALLATION

OVERALL LENGTH OF THE POLE SHOULD BE 20' WITH 4' IN GROUND, LEAVING 16'
CLEARANCE FROM THE GROUND TO TOP OF POLE. POLE SHOULD BE ROUND AND
(6) INCHES IN DIAMETER AT TOP OF POLE.



WEATHER HEAD SHOULD BE 2' FROM TOP OF POLE
WITH 2' TO 3' WIRE OUT OF WEATHER HEAD FOR SMEC
TO MAKE CONNECTIONS.

SERVICE ENTRANCE CABLE OR CONDUIT

#4 BARE COPPER GROUND WIRE

METER BASE APPROXIMATELY 5 1/2 TO 6 FEET
FROM GROUND LEVEL

OUTSIDE DISCONNECT BOX WITH RAIN TIGHT
MAIN SWITCH AND DEAD FRONT COVER.

OUTSIDE RECEPTACLE / GFI REQUIRED

* NOTE IF METER ON POLE IS BEING USED FOR CAMPER, A CAMPER PLUG MUST
BE SIZED FOR CORRECT AMPERAGE.
(50 OR 30 AMP) PLUG MUST BE COVERED WITH RAIN TIGHT IN-USE COVER.

GROUND ROD AND CLAMP GROUND LEVEL
POLE: FOUR (4) FEET IN GROUND

THERE ARE 3) TYPES OF GROUNDING THAT ARE ACCEPTED BY SMEC

- (1) Grounding at the overhead neutral
- (2) Grounding at the service entrance
- (3) Grounding at the meter base

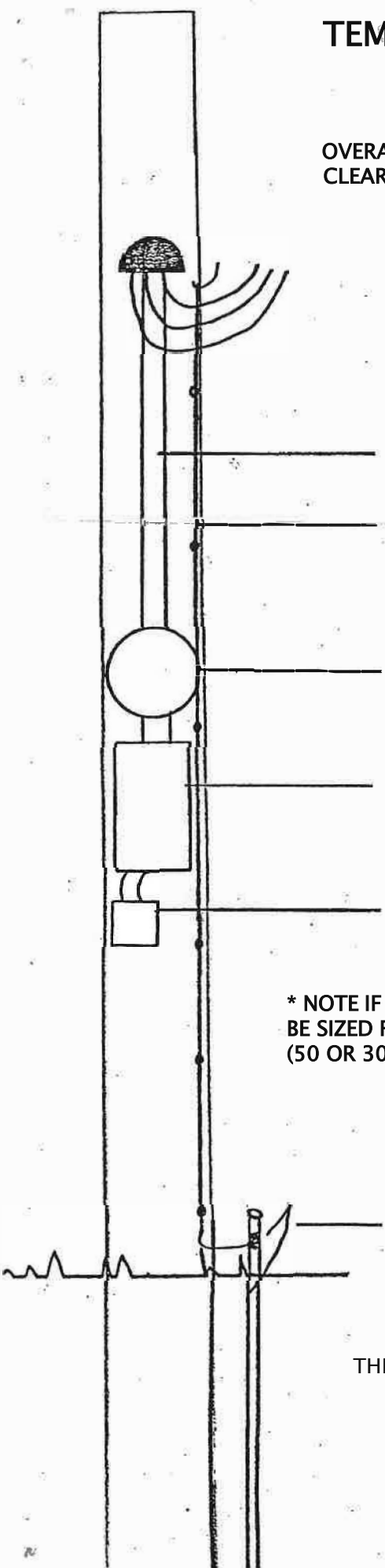

**IN-USE COVER
FOR CAMPER PLUG INSTALLATION AND WHEN DROP CORDS ARE PLUGGED
IN FOR AN EXTENDED PERIOD OF TIME.**

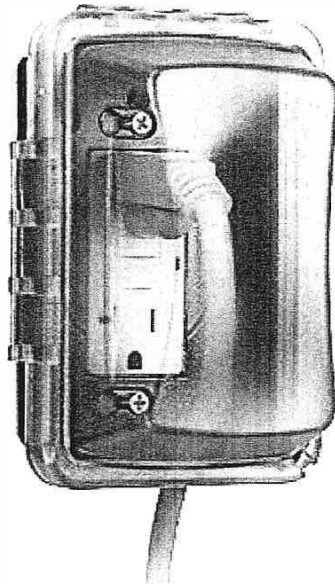

THIS IS A TYPICAL HOUSE POWER PANEL / METERBASE COMBO



MOBILE HOME INSTALLATION GUIDELINES

SERVICE REQUIREMENTS

Must complete application

Must pay deposit and any construction cost

Must obtain building or parking permit

(Rainsville, Hammondville & Collinsville must obtain from the City Hall)

Must obtain right of way easements

Must obtain meter base

Must obtain pole and guy location – required after mobile home is located on property.

ROUND POLE REQUIREMENTS:

Must be factory treated for earth contact to prevent decay

Must be at least 4' in the ground and guyed (if required)

Must be provided and installed by customer

Must be at least 20' long. Must be six (6) inches in diameter at top of pole.

Must be installed a maximum of 30' from the structure being serviced.

CONDUIT OR SERVICE ENTRANCE CABLE TYPE:

Weather head to outside disconnect:

Rigid or EMT with rain tight fittings.

Outside disconnect to inside panel:

Rigid, metallic and non-metallic or EMT

Pole 2' or less from mobile home

Conduit may be buried or above ground

Pole over 2' from mobile home conduit must be buried

**NOTE: EMT CONDUIT IS NOT APPROVED FOR BURIAL
USE SCHEDULE 40 OR SCHEDULE 80 PVC, OR RIGID METAL.**

**NOTE: DO NOT USE SERVICE ENTRANCE CABLE OR SER CABLE
FROM DISCONNECT INTO INSIDE PANEL OF HOME**

**SMEC REQUIRES CUSTOMER OWNED POLE TO BE WITHIN 30' OF MOBILE HOME.
IF FURTHER IN DISTANCE A SECOND DISCONNECT WILL BE REQUIRED.**

WIRING DIAGRAM

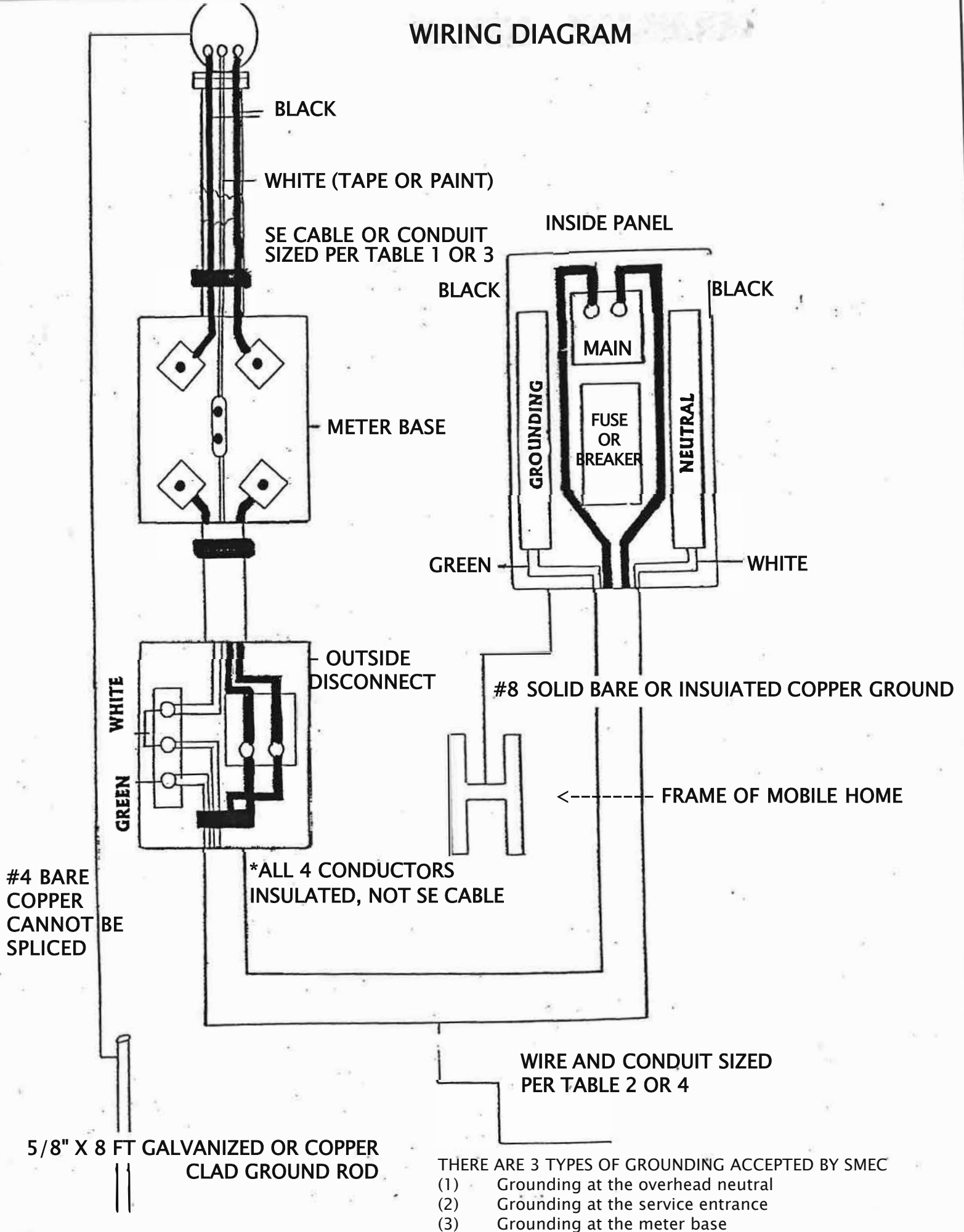

POLE DIAGRAM

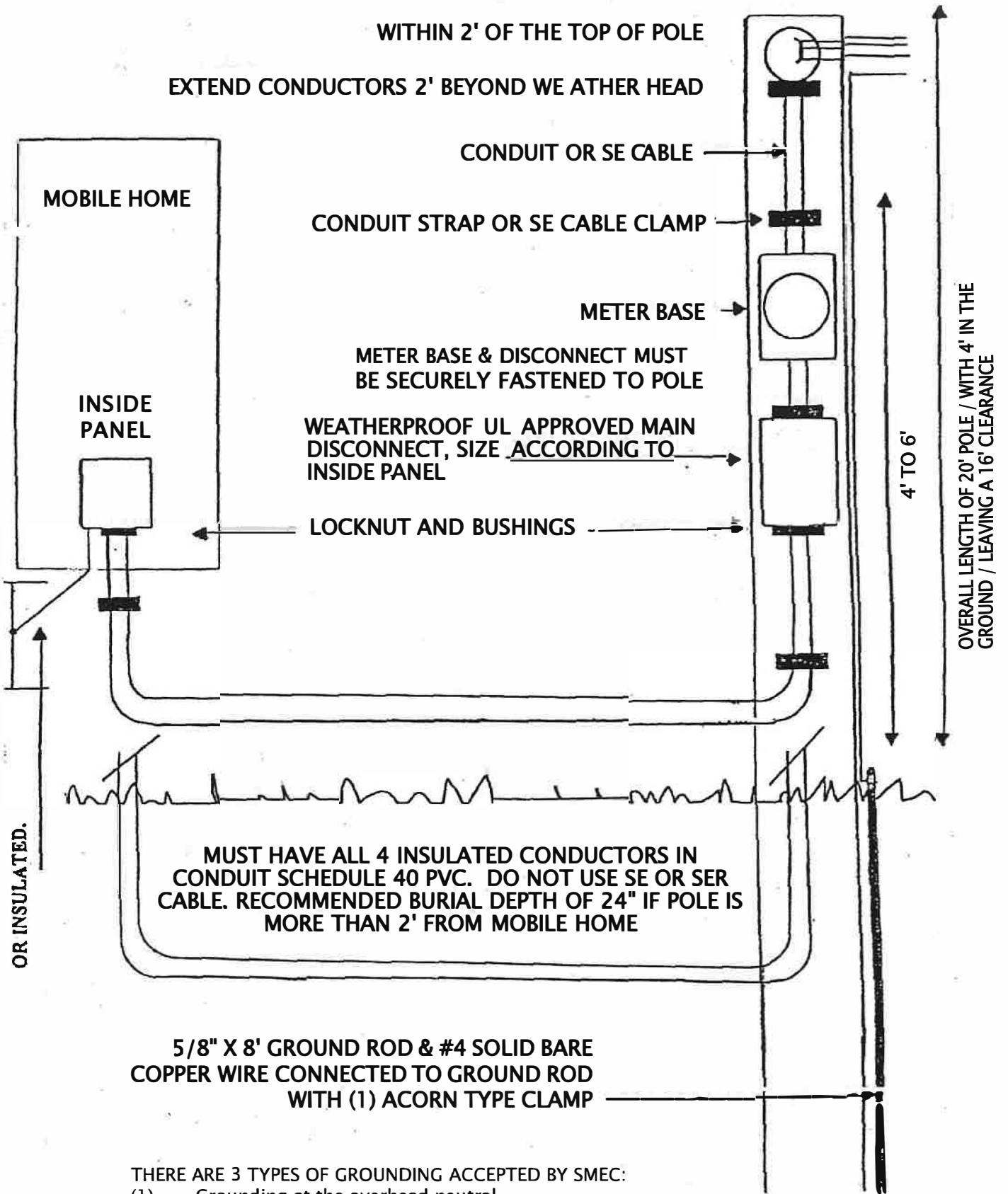

THERE ARE 3 TYPES OF GROUNDING ACCEPTED BY SMEC:

- (1) Grounding at the overhead neutral
- (2) Grounding at the service entrance
- (3) Grounding at the meter base

MINIMUM CONDUIT AND WIRE SIZE

 TABLE 1. Wire Size from Weather head to:

OUTSIDE DISCONNECT

COPPER	60A	100A	125A	150A	200A
2-Black	6	4	2	1	2/0
1-White	8	8	8	6	4
Conduit Size	1"	1 ¼"	1 ¼"	2"	2"

TABLE 3.

ALUMINUM

2-Black	4	2	1/0	2/0	4/0
1-White	6	6	6	4	2/0
Conduit Size	1 ¼"	1 ½"	2"	2"	2"

 TABLE 2. Wire Size from Outside Disconnect to:

INSIDE PANEL

COPPER	60A	100A	125A	150A	200A
2-Black	6	4	2	1	2/0
1-White	8	8	8	6	4
1-Green	10	10	8	6	6
Conduit Size	1 ¼"	1 ¼"	1 ¼"	2"	2"

TABLE 4.

ALUMINUM

2-Black	4	2	1/0	2/0	4/0
1-White	6	6	6	4	2/0
1-Green	8	6	6	4	4
Conduit Size	1 ¼"	1 ½"	2"	2"	2"

All wire must be temperature rated for 75 degree C (Distributor Requirement)

CONDUCTOR TYPES: Above ground in conduit - RH, WHH, RHW, RUH, THHN, THW, THWN, XHHW, and USE. Underground in conduit- RHW, THW, THWN, XHHW, USE. Direct burial USE (identified for underground use)

FOUR (4) INSULATED CONDUCTORS: Feeder from outside disconnect to inside panel shall consist of four (4)-insulated conductors sized and colored per Tables No. 2 & 4.

ALUMINUM CONDUCTORS: If aluminum wire is used, it shall be listed by the Underwriters Laboratory and all connections shall be approved for use with aluminum conductors and coated with oxide inhibitor.

POWER SUPPLY CORD: Mobile homes equipped with power supply cord and plug rated 40A or 50A shall be connected to outside service equipment through compatible female plug and shall be protected by a breaker or fuse of equal rating.

GROUNDING: A 5/8" x 8' galvanized steel or copper clad ground rod shall be driven 8' into ground. No. 4 CU solid wire shall connect the ground rod to service neutral at the weather head.

SPECIFICATIONS FOR UNDERGROUND SERVICE

- (1) SMEC Engineer will first determine if underground is feasible for Customer's location.
- (2) Engineer Department shall determine all underground meter base locations.
- (3) Underground cost must be paid before service is installed.
- (4) Service should not be any longer than 200'.
- (5) Customer to open and close ditch, minimum of 24".
- (6) Customer to supply 2 ½ inch schedule 40 electrical conduit for 200amp entrance (3" if more than 200amp) from meter base to butt of pole and install conduit with pull string.
- (7) Customer will also supply (2) – sweeping elbows, one at the meter base and the other at pole/pad mount transformer (**THIS ONE MUST BE RIGID/METAL**).
These are the only 2 directional fittings allowed.
- (8) Top of sweeping elbow must be at least 12" below ground level with enough conduit added to get above ground. 3" from butt of pole to sweeping elbow.
If 2 runs of conduit are used, 7" from pole.

** MUST USE ELECTRICAL PULL STRING **

DO NOT COVER DITCH UNTIL SMEC ENGINEER HAS PASSED INSPECTION

After the inspection is made, the Engineer will tell customer when to cover ditch with 12" of dirt and place warning tape also in ditch. Then cover completely after the warning tape is installed.

SMEC CREWS WILL WORK AS SCHEDULED. SMEC WILL FURNISH CONDUIT AND BRACKETS FOR SMEC POLE.

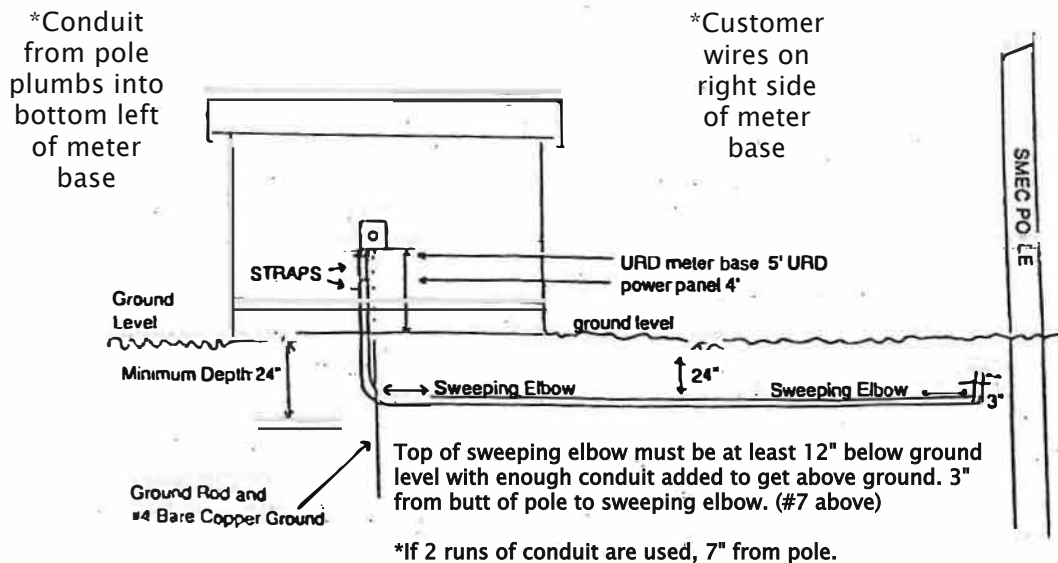

Has to be gray electrical conduit, not white pvc.

If meter base and inside panel are not back-to-back, the consumer will need to install an outside disconnect box, which will require using a four wire entrance and be located on right side of meter base.

When using 320a meter base & 2 disconnects, both disconnects must be to right side of meter base.

If further information is needed, contact SMEC Engineering Department.

SPECIFICATIONS FOR UNDERGROUND PRIMARY SINGLE PHASE LINE

Members will be required to open and close ditch.
Ditch will be in accordance with
Sand Mountain Electric Cooperative specifications.

Ditch requirements are as follows:

SMEC requires that the ditch be a minimum of 40" in depth with 2-1/2 inch Schedule 40 Electrical Conduit. If ditch is any less than the required depth, the ditch will have to be approved from SMEC Engineering Department.

SMEC provides the warning tape that must be placed in ditch. The conduit must be installed with electrical pull string inside, then approximately 1' of dirt, next install the warning tape, and complete filling the ditch with dirt. An Engineer from SMEC will give this warning tape to you after inspection is made on the ditch.

Because of added cost of underground cable, the member will be asked to pay an aid to construction cost in the amount of \$2.00 per foot for underground primary installation.

Revised: 7-10-92
Revised: 5-10-93
Revised: 5-10-99
Revised: 7-23-04

H-STRUCTURE FOR UNDERGROUND SERVICES

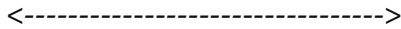
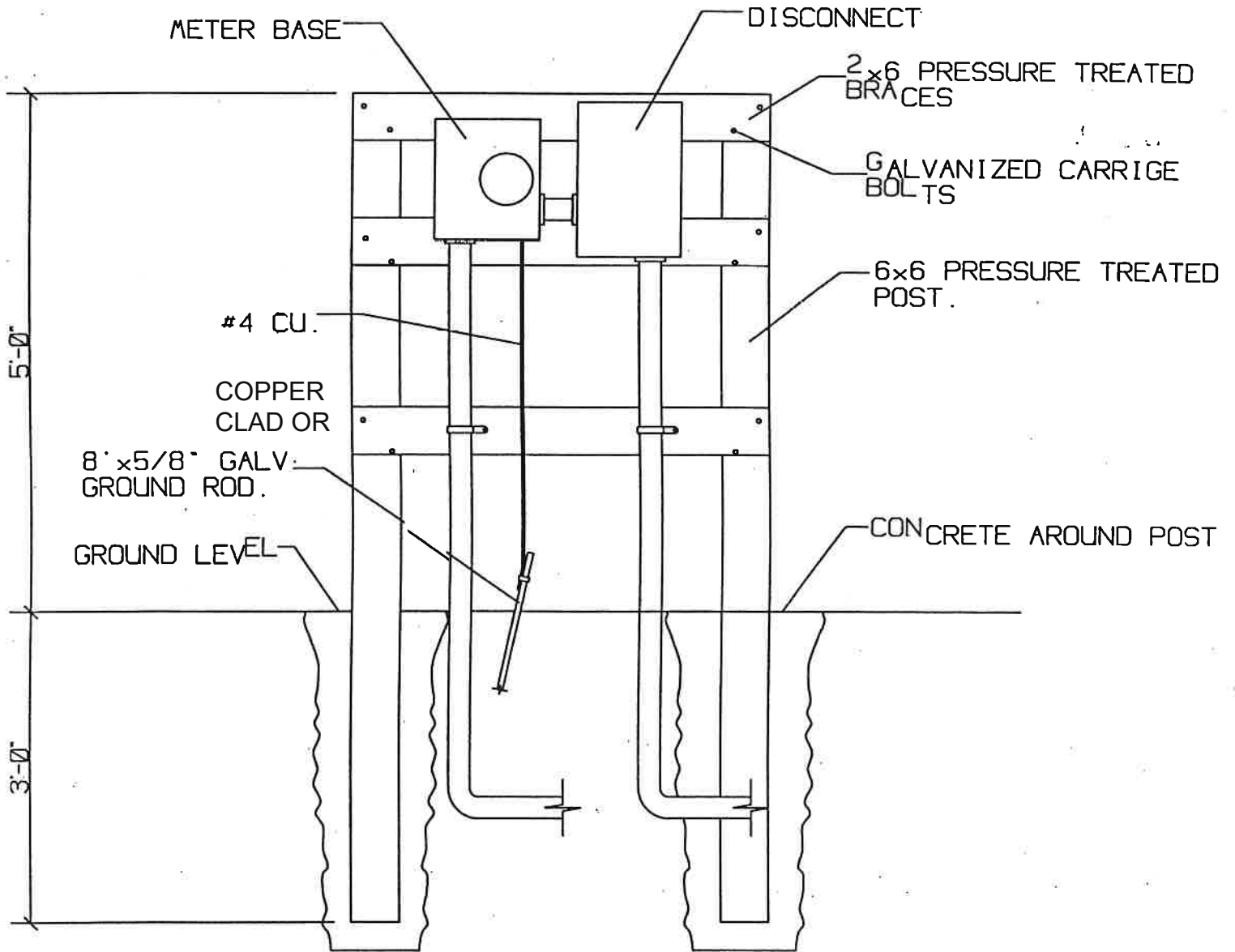

***Minimum of 4ft wide**

Pad Mount Transformer or Junction Pad

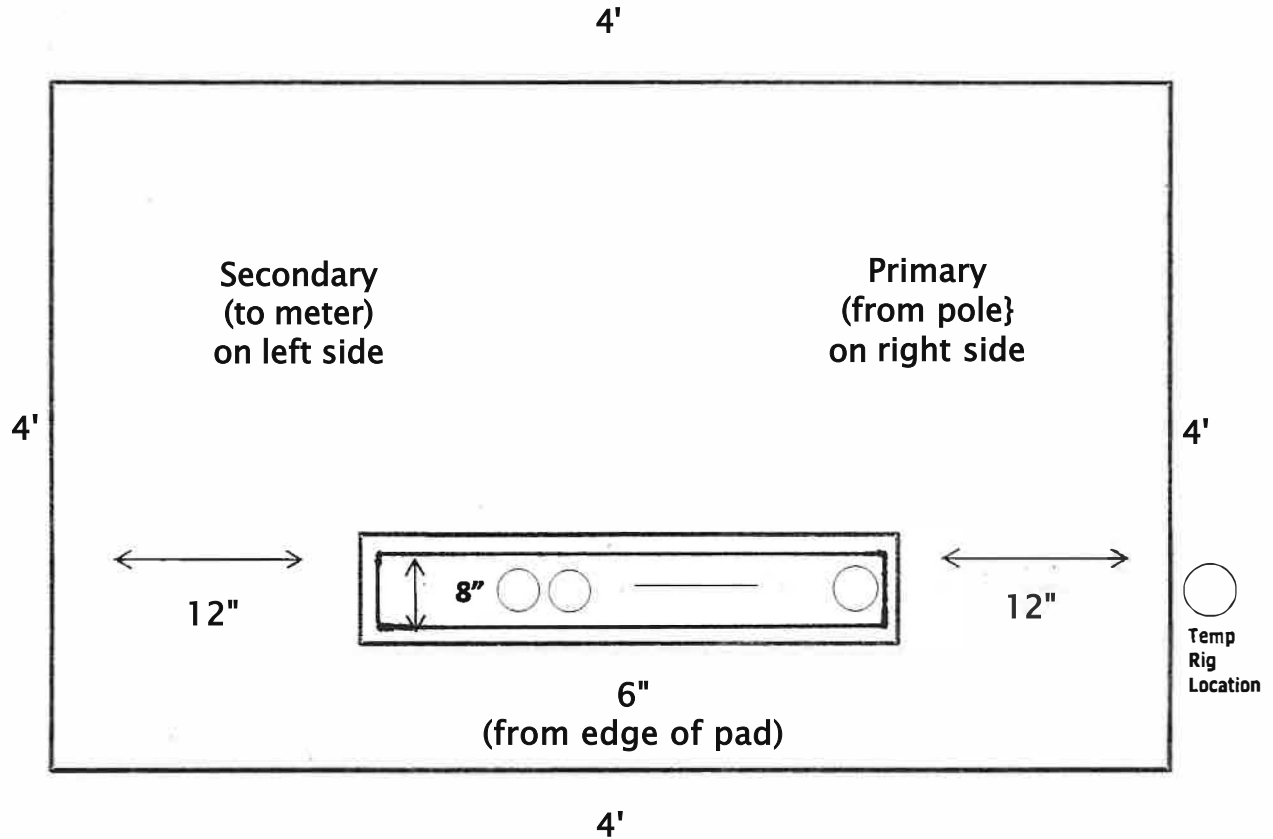

Concrete 6" deep
This pad is for 25-167 KVA Pad Mount Transformer
Openings Stay the Same

ANTENNA SAFETY

The erection and maintenance of antennas presents a problem that is very closely allied with electrical wiring. In many cases the same people are engaged in both types of work. In view of this, we are including within the scope of these regulations the following recommendations for the safe erection and operation of such antennas, we sincerely urge you as homeowners and as wiring contractors to abide by them in the interest of your safety as well as that of others.

1. Do not erect any antenna in such a location that the antenna, mast, guys or any fixture of the installation could reach a power line during its erection or if it should fall.
2. Install adequate binding jumpers to all pipe joints, guy attachments and metal accessories to assure a solid, low-resistance path to an approved driven ground rod equipped with an approved type clamp.
3. Each conductor of each lead in cable should be provided with a lightning arrestor approved for such application. The arrestor shall be located near the point of cable entry into the house and also near the driven ground rod equipped with an approved type clamp.
4. All antennas should be of adequate mechanical strength and guyed in such a manner as to withstand the elements to which it will of necessity be exposed. This consideration should include possible windstorms and ice conditions. The practice of attaching antennas to chimneys is not considered wise, as the possible leverage action of an antenna is substantial.
5. All antennas and installations comply with articles of the National Electric Code.

FINAL INSPECTION

SMEC's Engineering Department Construction Engineer will make final electrical inspection of service entrance before service can be energized. It is also necessary that the Co-op member file a signed application for electric service.

SMEC RESERVES THE RIGHT TO CHARGE A FEE FOR INSPECTION TRIPS MADE AFTER THE INTIAL ROUTINE INSPECTION.